

Effects of Blowdown Flows on Isolation Valve Operability

Kevin G. DeWall

EG&G Idaho, Inc., Idaho Falls, ID USA

ABSTRACT

This paper presents the results of the USNRC/INEL^b testing of isolation valves under high-temperature/pressure boiling water reactor (BWR) line break conditions. The purpose of the testing was to provide input to the technical basis for resolving the NRC's Generic Issue 87. Two representative nuclear valve assemblies were cycled under design basis conditions simulating a pipe break in the reactor water cleanup supply line. The effect of the resulting hydraulic loadings on valve operability, especially stem forces during valve closure, were studied. Both valves isolated flow during all tests; however, valve stem forces were much higher than anticipated. Tests showed that proper operator sizing and torque switch settings depend on the identification of correct values for the sizing equations, and that values used in the past may not be conservative for all valve applications.

INTRODUCTION

The objective of this research is to determine the functional requirements for isolation valves in high-temperature/pressure BWR piping systems where such valves must close against high flows in the event of a pipe break outside containment. The results will provide the technical basis in the resolution of Generic Issue 87 (GI-87), "Failure of HPCI Steam Line Without Isolation." The research also provides information applicable to two additional regulatory items: (1) Generic Issue II.E.6.1, "In Situ Testing of Valves" and (2) IE Bulletin 85-03, "Motor Operated Valve Common Mode Failures During Plant Transients Due To Improper Switch Settings."

GI-87 applies to those process lines that communicate with the primary system, pass through containment, and contain normally open isolation valves. Three process lines meet these criteria: (1) the high pressure coolant injection (HPCI) steam supply line, (2) the reactor core isolation cooling (RCIC) steam supply line, and (3) the reactor water cleanup (RWCU) supply line. Of the three, the RWCU supply line is the one in which an unisolated break would have the greatest safety impact, so we configured the hot water flow isolation testing to provide information on valve operability questions associated with

a. Work supported by the U.S. Nuclear Regulatory Commission, Office of Nuclear Regulatory Research, DOE Contract No. DE-AC07-76ID01570, under the direction of Dr. G. H. Weidenhamer, Technical Monitor.

b. United States Nuclear Regulatory Commission; Idaho National Engineering Laboratory.

the RWCU environment (subcooled water flashing to steam). Most RWCU containment isolation valves are 6-in., 900-lb, flexible-wedge gate valves with Limitorque electric motor operators.

BACKGROUND

Figure 1, a cutaway drawing of a typical motor-operated gate valve, shows the components of importance to this discussion. The forces needed to close the valve and isolate flow must overcome the resistance imposed by three loads: (1) the disc frictional drag load caused by the differential pressure across the disc as the valve closes, (2) the stem rejection load caused by static pressure on the stem, and (3) the packing drag load. Industry has developed a set of equations for use in sizing motor operators. The first equation in this set predicts the total stem force, as detailed below. Each manufacturer modifies the variables in the equation slightly; however, in the long run the application of the equation is the same.

$$F_t = \mu_d A_d \Delta P \pm A_s P + F_p \quad (1)$$

where

- F_t = total stem force
- μ_d = disc factor
- A_d = disc area
- ΔP = differential pressure
- A_s = stem cross-sectional area
- P = stem pressure
- F_p = packing drag load.

The disc factor normally used for wedge-type gate valves in Equation (1) is 0.3; however, one manufacturer has recently increased this to 0.5 for high flow applications. Note that in this equation the stem rejection load can be either positive or negative depending on whether the valve is closing or opening. This is because the stem rejection load is always in a direction out of the valve body; this load resists valve closure and assists in opening the valve. The packing load is a constant that depends on the packing design, gland nut torque, and direction of operation. The service conditions used in the force equation are supplied by each individual plant.

Motor operators control operator output torque, not valve stem thrust. Thus, the sizing of the operator and the setting of the torque switch in motor-operated gate valves must conservatively consider the conversion of operator output torque to valve stem thrust. This conversion is the second equation in the set of motor operator sizing equations. The torque to thrust relationship normally used in sizing motor operators depends on a stem factor as shown below.

$$T = \mu_s F_t \quad (2)$$

where

- T = operator torque
- μ_s = stem factor
- F_t = total stem force
[from Equation (1)].

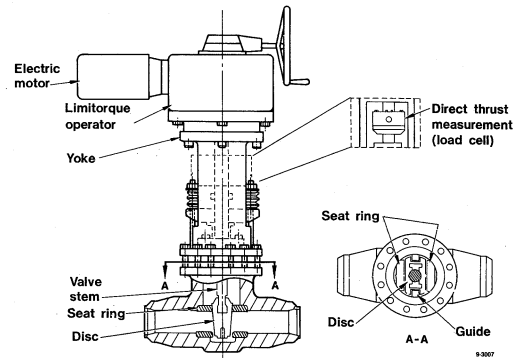

Figure 1. The test program used two motor-operated valves similar to the typical valve shown here; a load cell was installed in each valve stem, as shown.

The stem factor is a function of stem diameter, thread pitch and lead, and the coefficient of friction between the operator stem nut and the valve stem. For a given stem and stem nut, the only variable that can change the stem factor is the coefficient of friction. Normally it is assumed that only the condition and lubrication of the stem/stem nut threads can significantly alter the stem factor.

TEST PROCEDURE

In this research program, two full-scale representative nuclear valve assemblies were cycled under full-scale RWCU pipe break conditions. The valves were 6-in., 900-lb, flexible-wedge gate valves manufactured for this test program. Valve A had a normal guide design and large disc to body guide clearances, while Valve B had a hardfaced guide design and tighter clearances. The valves were powered by Limatorque SMB type ac motor operators. To ensure valve closure and data collection at the greater-than-normal loadings, Valve A used a larger, greater capacity motor operator than would normally be used. Valve B's motor operator was sized in accordance with current practices for the highest test pressure. With their differences in internal and friction-bearing surface design, the two valves represented a large number of motor-operated valves used in nuclear plants today. In each valve, the stem was cut, the yoke lengthened, and a highly accurate, high-temperature load cell (Figure 1) installed so that direct measurements of stem force could be obtained.

The test system featured a large water tank, heated and pressurized so that various system water conditions could be established and regulated: 600, 1000, and 1400 psig; 350, 400, 480, 530, and 580°F. The test program was designed to determine valve operability and to measure the forces needed to close and open the valves during blowdown under these conditions. The test valve was mounted in a 6-in. pipe section (the balance of the test system was 10-in. piping) with appropriate fittings for obtaining temperature and pressure measurements. A fast acting, hydraulically operated valve was positioned so that when it was actuated, pipe break flow through the test valve would be initiated and the system's fluid abruptly dumped to the atmosphere.

Upon installation in the test system, each valve assembly was subjected to a typical ANSI B16.41 functional qualification test, including the valve leakage test (Annex A), cold cyclic test (Annex B), and hot cyclic test (Annex C). These tests provided a baseline characterization of valve assembly operation for comparison with the later testing. Annex G, flow isolation, was the subject of this test program and thus was not performed as a part of the qualification series. Fourteen flow isolation test series were performed during the test program, ten on Valve A and four on Valve B.

TEST RESULTS AND INTERPRETATION

Valve Stem Force

Throughout the testing, both valves repeatedly performed their design basis function, although at a higher than calculated thrust. In generating the analytical thrust calculations for comparison to measured thrusts (stem forces), we used actual response histories for all the variables in Equation (1) except disc factor. This comparison of measured forces to values calculated using both 0.3 and 0.5 disc factors provides a common basis for discussing valve operating characteristics.

Figure 2 illustrates this comparison of actual measurements to calculated values for Valve A closure during high flow isolation at normal BWR operating hydraulic conditions of 1000 psig and 530°F. The figure shows the actual stem compression (negative values) increasing as the valve closes, until the compression reaches a peak when the flow path is finally blocked. Then the stem compression decreases to a value representing the force required to slide the disc on the full seat ring to the final seating position. Finally, the force increases sharply through torque switch trip to the final stem compressive load (at approximately -40,000 lb, not shown in Figure 2). This additional stem force beyond torque switch trip is due to the circuit dropout time and the momentum of the operator motor. Figure 2 also includes two calculations using 0.3 and 0.5 disc factors. For this 10°F subcooled case, the

calculations do not envelope loads encountered during the test. Notice how the shape of the curve changes drastically from about 25 to 32 seconds. The behavior of the valve in this range does not appear to have linear disc frictional drag characteristics.

We found that two factors can contribute to differences between the calculated and measured results: the degree of fluid subcooling, and the internal design of the valves. A comparison between Figures 2 and 3 shows how the thrust needed to seat the valve varied with the degree of upstream fluid subcooling. Figure 3 shows the forces measured during another test of Valve A, at the same pressure (1000 psig) but with 140°F subcooling in the fluid. The only difference between the two tests was the initial fluid temperature. The calculation using the 0.3 disc factor does not envelope the response in this test, but the 0.5 disc factor marginally envelopes the response. Note in Figure 3 that with the increase of subcooling, the response of Valve A is more linear, and the calculated forces compare more favorably with the measured forces. Measurements of pressure and temperature show that flashing occurred upstream of the valve in the test with 10°F subcooling; we suspect that the resulting two-phase flow through the valve may have contributed to the non-linear response of the valve (Figure 2).

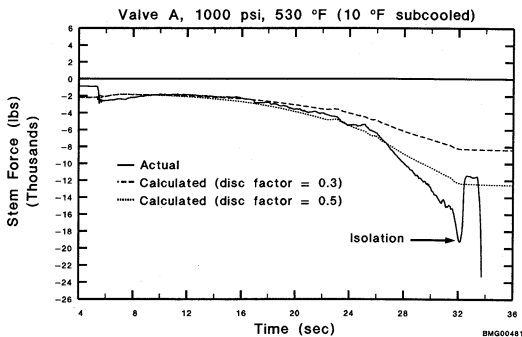

Figure 2. In this test, the loads measured during closing were greater than the loads calculated using 0.3 and 0.5 disc factors.

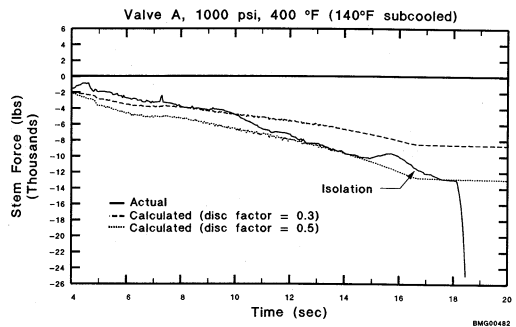

Figure 3. With an increase in subcooling, the calculated loads compare more favorably with the measurements.

Valve internal design can also greatly affect valve closure forces. Figure 4 shows the stem force trace for Valve B flow isolation at normal BWR operating conditions (10°F subcooled). Because of its larger port and stem size and a packing design with greater drag, Valve B would be expected to need about a three percent higher force during closing than Valve A. A comparison of Figures 2 and 4 shows this to be true for the first half of the closing stroke and during the seating period at the end of the valve cycle. However, during the last half of the valve's cycle, down to flow isolation, Valve A needed much higher forces than Valve B. Also, Valve B exhibited linear behavior throughout the closure stroke, in contrast to the nonlinear behavior of Valve A.

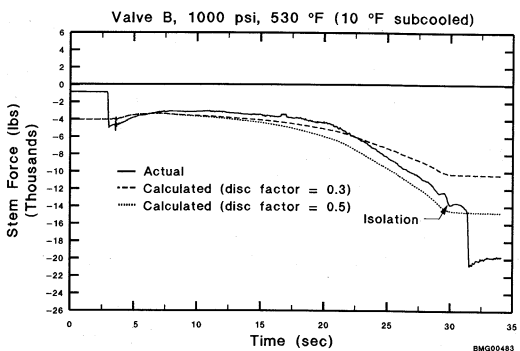

Figure 4. The response of Valve B is more linear than that of Valve A; the calculation using a 0.5 disc factor marginally envelopes the measured load, but the 0.3 calculation is not conservative.